

Product Specification



270 Scientific Drive, Suite 14
Norcross, Georgia 30092

www.nexxspan.com

tel 678.578.7800

fax 678.578.7840

Heavy Duty Equipment Management Rail System Owner Furnished and Contractor Installed (OFCI)



1.0 **General**

- 1.1 The Equipment Management Rail System as shown on drawings and specified herein shall be as manufactured by Nexxspan Healthcare, LLC. The system shall provide a means to support and secure hospital medical equipment such as monitors, infusion pumps, flow-meters, regulators, medical gas outlets, etc., by utilizing a snap-action adapter that allows easy repositioning of equipment by the nursing staff.
- 1.2 Shop drawings for approval are NOT required. Elevation drawings will be provided if requested.
- 1.3 Accessory manufacturer shall provide documentation as required by Owner. Owner shall be responsible for documentation review and coordination with manufacturer in regard to shipment and delivery.
- 1.4 The system shall be owner furnished and contractor installed in strict accordance to Nexxspan Healthcare, LLC installation instructions. The installing contractor shall be responsible for compliance with all local, state, and national codes that may be applicable to this installation.
- 1.5 Nexxspan Healthcare, LLC. reserves the right to provide the system with improvements in design and/or material at time of manufacturing.

2.0 **Equipment Management Rail**

- 2.1 The Equipment Management Heavy Rail, shall be a seamless, extruded aluminum profile finished with clear anodizing. The rail shall contain a groove for attaching an adapter that supports the specified hospital accessories and equipment as provided by owner. To prevent accidental dislodgment, the groove and adapter shall be designed so that the adaptor required a 7-degree tilt for attachment. The rail shall also provide the means for inserting a decorative color inlay the length of the rail, and closure caps at each end.
- 2.2 RAIL shall be specified in increments of one foot, from a minimum of one foot to a maximum of ten feet, or be of special lengths as shown on drawings to accommodate special room conditions. The Rail may be joined together with the use of a JOINER piece to provide lengths greater than ten feet.
- 2.3 The manufacturer shall pre-drill the rail on sixteen-inch centers (minimum) with the exception of a 1' piece of rail which has two mounting holes on eight-inch center. The Rail may be field drilled by the installer to meet specific job site conditions.
- 2.4 END CAPS shall be constructed of injected molded thermoplastic & shall resist most hospital cleaning and disinfecting chemicals. The color shall be Light Grey and molded throughout the material.
- 2.5 DECORATIVE INLAY shall be supplied by the manufacturer for installation by the Owner. Inlay shall be constructed of extruded thermoplastic meeting UL-94-V-0 burning specification and resist most hospital cleaning and disinfecting chemicals. Color shall be light grey and integral to the material. Alternate colors are available at an additional cost.

3.0 **Mounting Hardware**

- 3.1 Mounting hardware shall be available from the Rail manufacturer at an additional cost. Hardware shall be available to allow the Rail to be either flush mounted or spaced two inches from the hospital wall using standoffs. Architect shall specify and show on drawings whether system is to be mounted flush or utilize spacer hardware.

3.2 FLUSH mounting hardware shall be available for mounting to steel studs or backing, drywall or masonry walls. Architect shall specify and show on drawings wall structure to be used. Flush mounting hardware shall consist of the appropriate screws in a quantity to mount rail on sixteen-inch centers.

3.3 STANDOFF mounting hardware shall be available for mounting to steel studs or backing, drywall or masonry walls. Architect shall specify and show on drawings wall structure to be used. Standoff mounting hardware shall consist of a machined aluminum spacer and the appropriate screws in a quantity to mount rail on sixteen-inch centers.

3.4 When rails are mounted with the above approved hardware and in strict accordance to manufacturers installation instructions, rail shall accommodate function loading up to 62 lbs between 16" centers. The 1' rail shall accommodate 25 lbs of direct weight.

4.0 **Installation**

4.1 Contractor shall supply and install system in accordance with Manufacturers installation instructions.

Installation Pictures

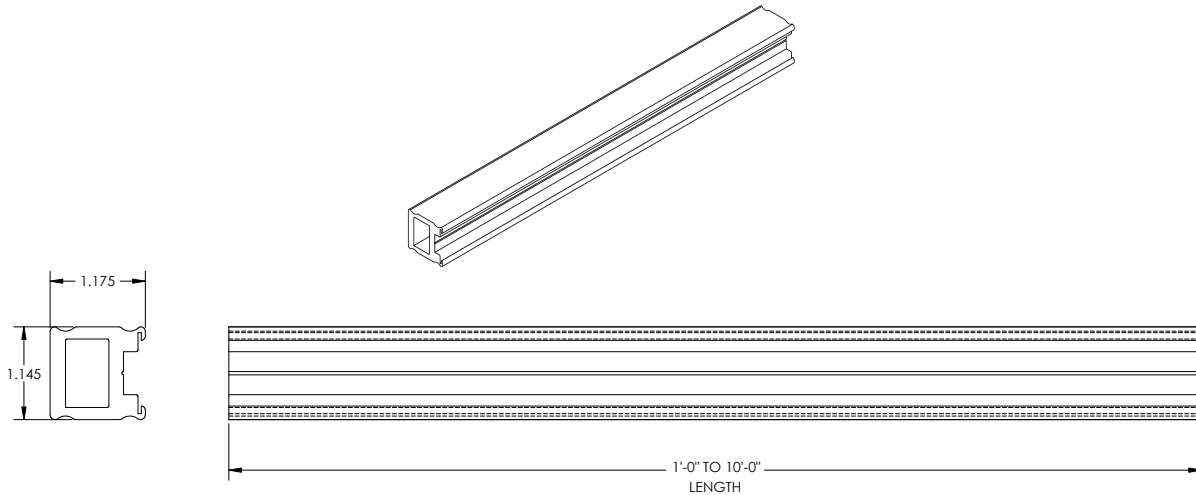

- Material:** Aluminum - finished with clear anodizing
- Length:** 1' - 10'
- Inlay:** Included - Standard Color is Light Grey, custom colors at an additional cost
- Encaps:** Included - Standard Color is white
- Installation:** Wall backer should be installed for new construction
Rail should be attached to studs using the installation instructions provided.
- Hardware:** Available at an additional cost